

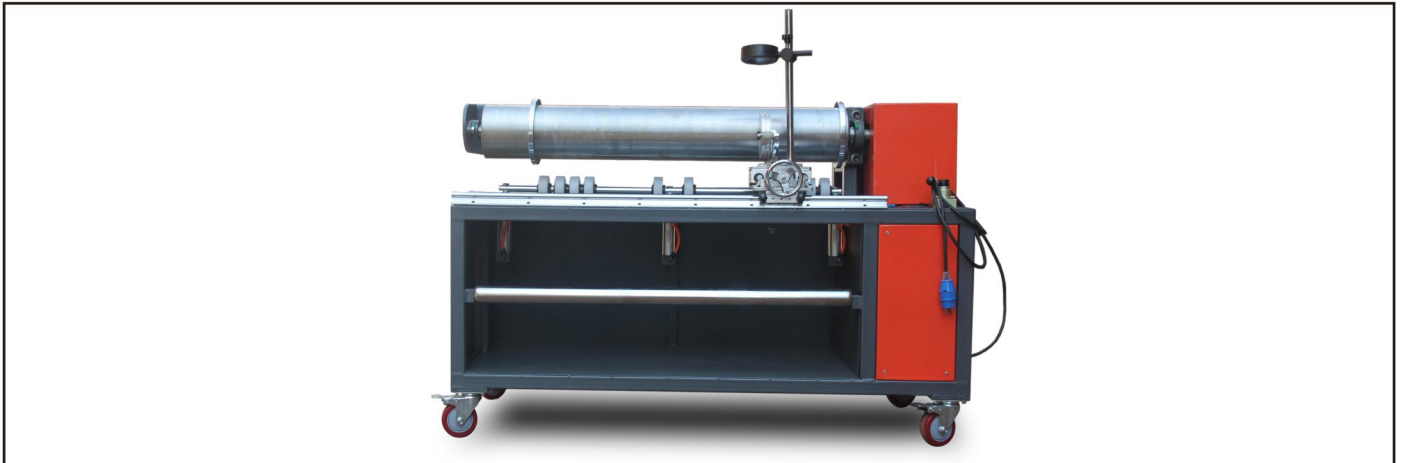

Operation Manual

Holo QB1000 V Guide Welder



Manufacture: WENZHOU HOLO INDUSTRIAL EQP MFG CO.,LTD

Factory add: RM201, BLDG3, NO188 WANGXIN ROAD, DONGSHAN STR. RUIAN ZHEJIANG, CHINA

TEL: +86 577 65682000

FAX: +86 577 65916651

Web: www.holobelt.com

Table of Contents

Introduction and air pump.....	pg. 1
Specification and 2Meter design.....	pg. 2
General safety rules.....	pg. 3
Safe Operation.....	pg. 4-9
Other Optional Accessories.....	pg. 10
Common problems and solutions.....	pg. 11

Automatic belt welding machine

Be sure to read and completely understand this procedure before applying product.
Be sure to select the proper PREFORMED product before application.

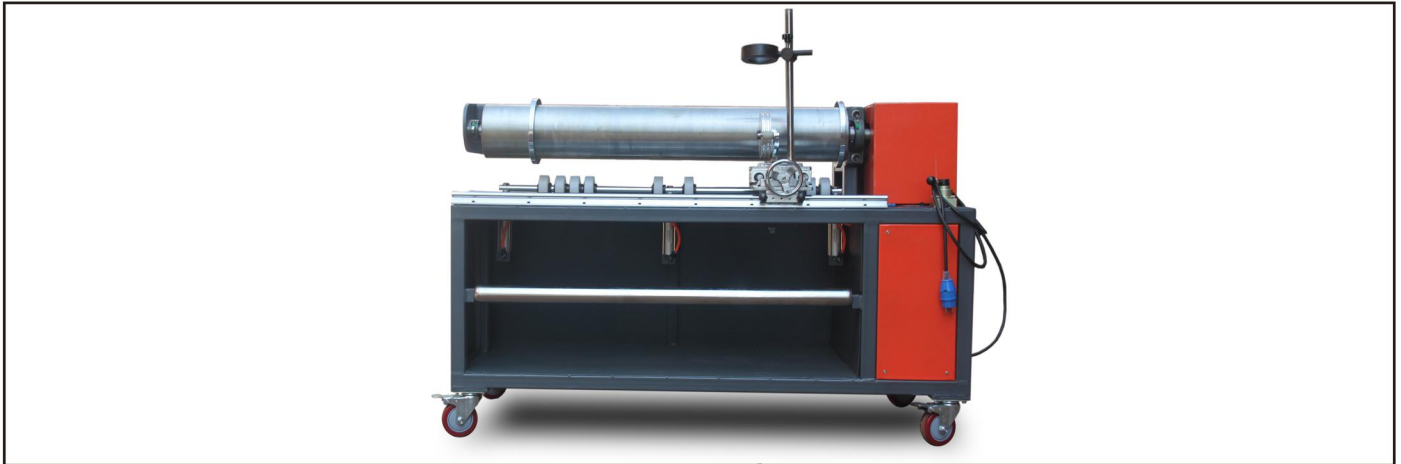

CONSIDERATIONS:

This device uses 220V power supply, and requires an air compressor.

MAIN COMPONENTS

- | | | |
|-------------------------|------------------------|---------------------------|
| · Heat gun | · Roller | · Lead rail |
| · Belt press pole | · Power switch | · Lateral hand wheel |
| · Guide wheel | · Speed control switch | · Universal wheel |
| · Belt feed panel | · Air inlet port | · Longitudinal hand wheel |
| · Engine | · Pressure wheel | · |
| · Pressure wheel switch | · Distribution Box | · |

FEATURES AND BENEFITS:

The equipment used to solve ring type industrial belt defensed is connected with the guide bar, with automatic belt guide article defensed connection function, welding infinite perimeter ring belt, defensed the joint width is 1.5m. 1 minutes effectively defensed the bonded length is 8m. Guide the motor Power 350W, can drive commonly used industrial belt.

YOU MUST HAVE AN AIR PRESS BEFORE YOU USE IT.



Air compressor

HOLO® V GUIDE WELDING MACHINE

WENZHOU HOLO INDUSTRIAL EQP MFG CO.,LTD

Tool Specification

Specifications		value
Length	(mm)	1450
Width	(mm)	800
Height	(mm)	1000
Net weight	(kg)	170
Packing weight	(kg)	200
Package volume (L*W*H)	(mm ³)	1600*930*1230
Power	(W)	550W
Maximum speed	(m/sec)	0.2
Effective width	(mm)	1000

2 Meter Extension frame

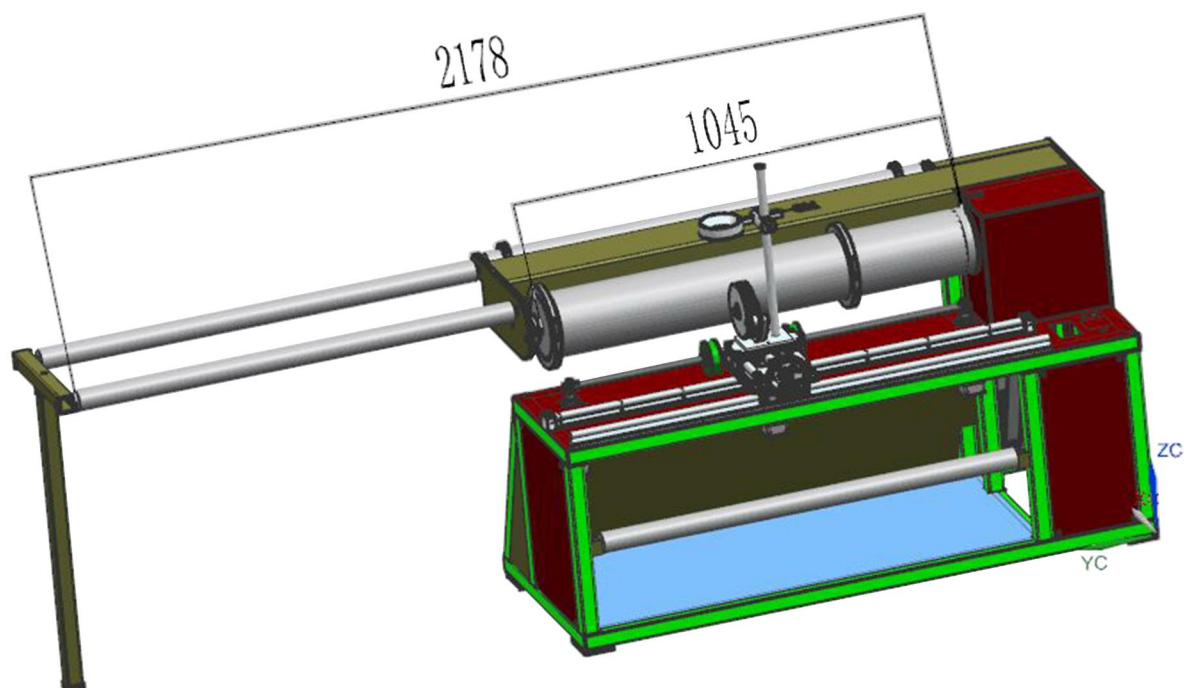

HOLO® Welding machine Safety and Operating Manual

Exatra Case

1 the equipment recommended configuration LANSITE handheld DSH-D type hot air gun. This device parameters: 220V rated voltage and insulation strength 3750V, rated frequency 50Hz and quantity 13.8 m³ / h, power 1600W, wind pressure 3000pa, temperature range 40-700 Celsius degree.

2 when the operation, the heater power to the lowest level, after the power of the welding needs, and then gradually improve, to achieve the desired temperature of welding.

3 before the stop should be the first to point to the "0" scale, hair number of minutes, until the gun barrel cooling can be shut down, so as not to heat the body. Hand in



General Safety Rules

[Save These Instructions](#)

Signal words:

“DANGER” indicates an imminently hazardous situation which, if not avoided, will result in death or serious injury. The signal word is limited to the most extreme situations.

“WARNING” indicates a potentially hazardous situation which, if not avoided, could result in death or serious injury.

“CAUTION” indicates a potentially hazardous situation which, if not avoided, may result in minor or moderate injury. It may also be used to alert against unsafe practices.

Safety Symbol



This international safety symbol is used to identify and call attention to specific safety matters.

Safety Information

To Avoid Severe Personal Injury or Property Damage, read carefully and understand the following Safety Precautions.

Overall Safety rules

⚠ DANGER

This action will send a more abrupt collision sound, the operator needs to predict that, in order to avoid panic!

⚠ DANGER

Press wheel drive rapid upward pressure roller fixing belt while open the pressure valve.

⚠ WARNING

Frequency is proportional to the temperature of the hot air gun.

⚠ CAUTION

manual welding need to use hand welding hot air gun, please prepare in advance.

⚠ CAUTION

Bars cutting length shown above is ideal, it will facilitate the completion of the final welding by hands, please pay attention!

HOLO® V GUIDE WELDING MACHINE

WENZHOU HOLO INDUSTRIAL EQP MFG CO.,LTD

Safe Operation of Welding machine

MATTERS OF PARTICULAR

This manual will be referred to the key components of the following, if failed to account for the location, please refer to the map to understand.

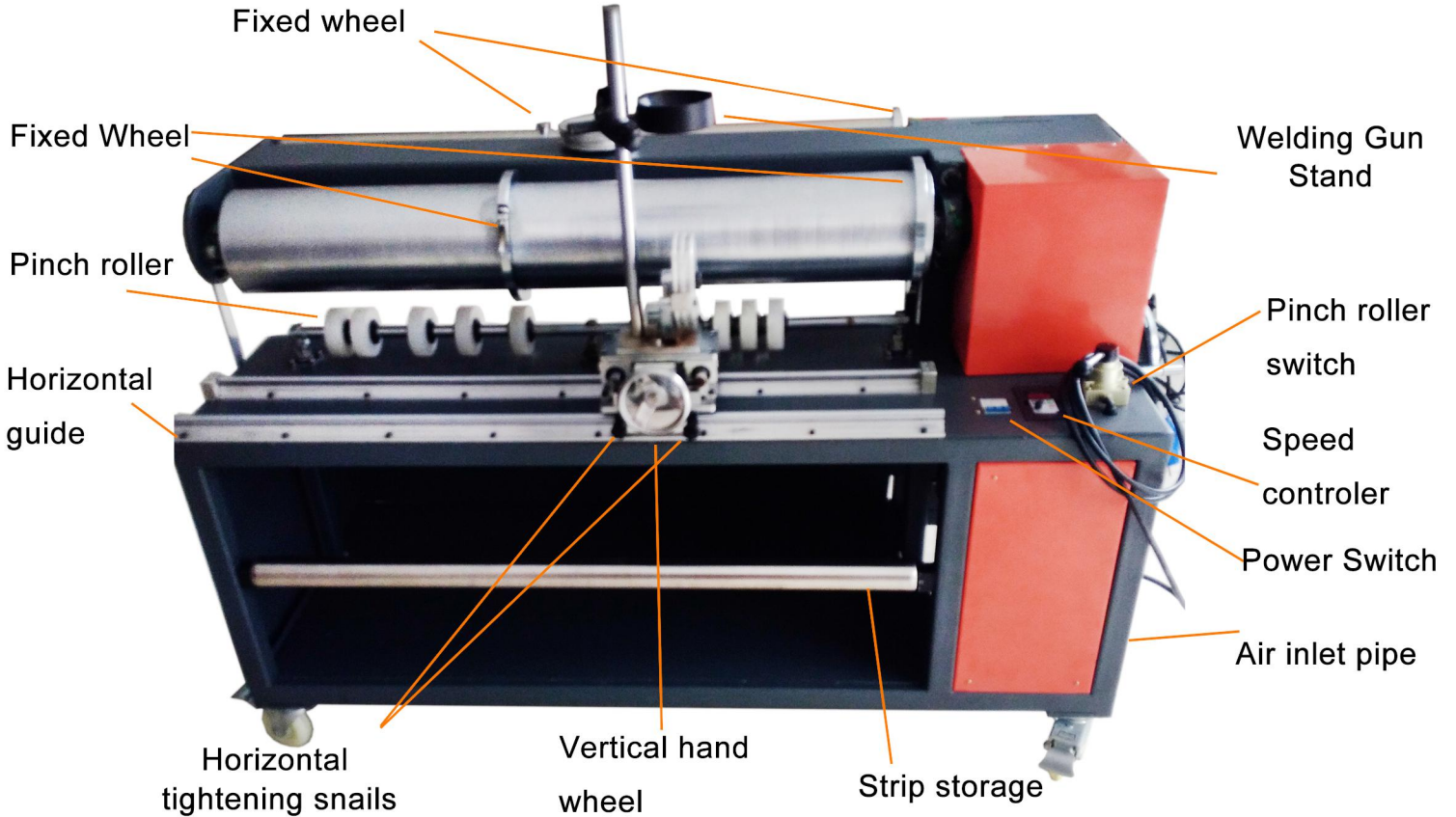

Lateral hand wheel has been changed to two horizontal fastening

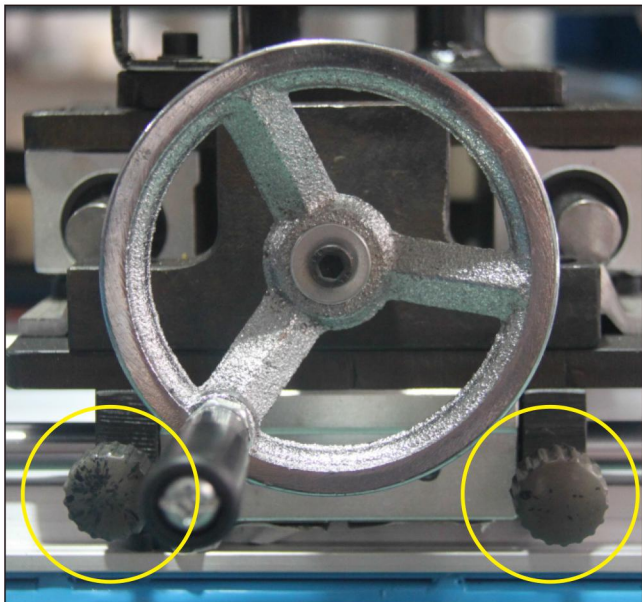

Press wheel switch appearance has been changed to the following diagram



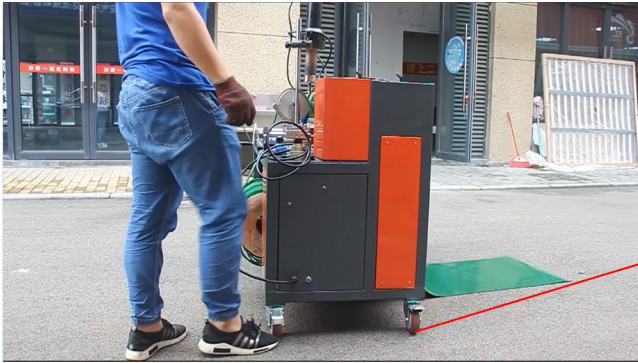

1. Fix the caster brakes

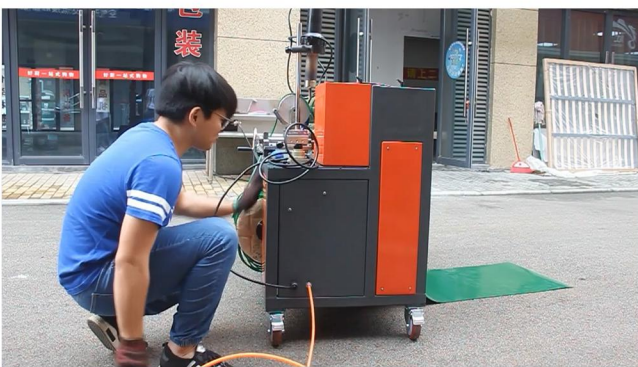

2. Connect the air pipe, open the air compressor

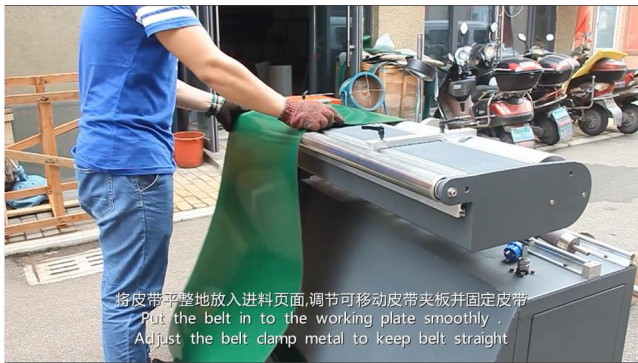

将皮带平整地放入进料页面,调节可移动皮带夹板并固定皮带
Put the belt in to the working plate smoothly .
Adjust the belt clamp metal to keep belt straight

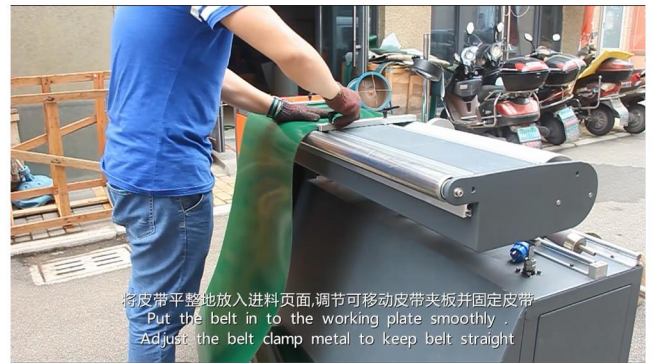

将皮带平整地放入进料页面,调节可移动皮带夹板并固定皮带
Put the belt in to the working plate smoothly .
Adjust the belt clamp metal to keep belt straight

3. Put the belt into the working plater, adjust the belt clamp metal to fix the belt



测量好导条在皮带端焊接的距离
Measure the distance where guide should placed on the belt

4. Measure the distance requested

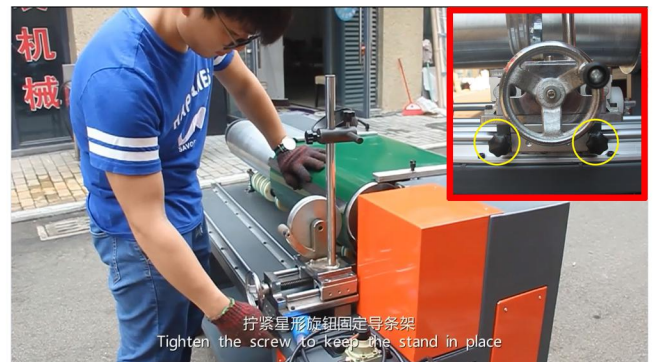

拧紧星形旋钮固定导条架
Tighten the screw to keep the stand in place

5. Tighten the screw to keep the stand in place



6. Let the belt through the pinch roller

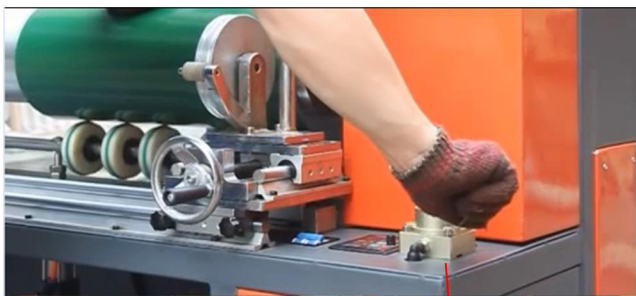

7. Open air valve, pinch roller raised up and fix the belt



8. Put the guide on the guide storage roller



Avoid the pinch roller to press the fixed wheel and the V guide

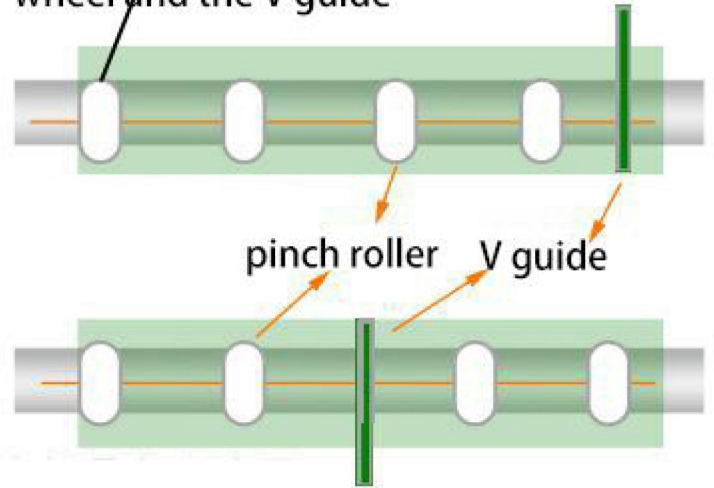

Warning

Pinch roller should move to the belt blank area, not touch the fixed wheel and V guide



9. Put the guide through the mould, adjust distance between mould the belt by rotary handle.

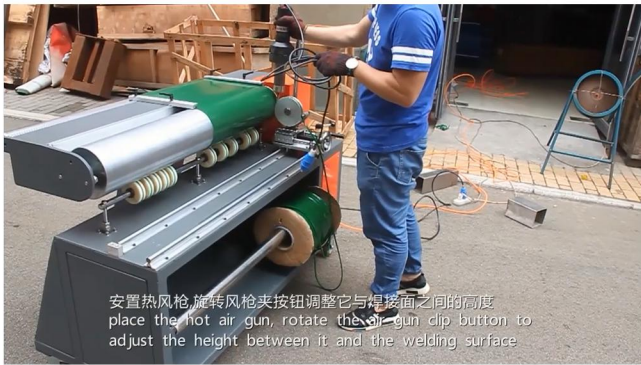

10. Fix the welding gun, adjust the welding position.



⚠ warning

Make sure the two locations after the hot air gun is loaded to the upper fixing ring of adjustment device:

- i: Hot air gun and stand needs to be stable, prohibit swing or skew.
- ii: Make muzzle close to the belt and bars, but not touch. If not in the middle, it can be fine-tuned by adjustment device.

Muzzle contacting with the belt or the bar may damage the belt surface or fusion inadequate!



The hot air gun is loaded to the upper fixing ring of adjustment device. Adjust the hot air gun and make it aligned in the middle position between the bar and the belt. Hot air gun positions may need to be fine-tuned this procedure.



After connecting the power, turn on start switch on the heat gun, and start setting the required temperature by the red temperature control knob.

After the hot air gun temperature adjustment is completed, it starts heating automatically. It will be completed within approximately 2-3 minutes.

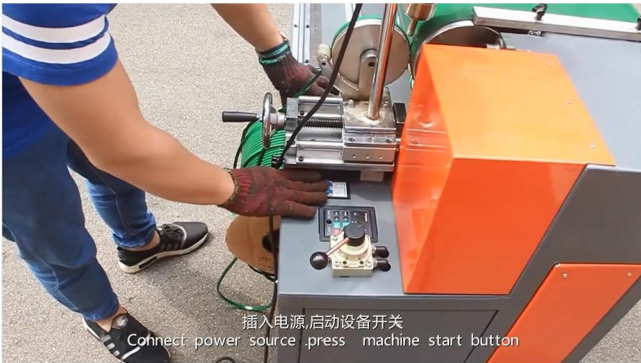

11.Open the power



12.Use the speed conroller to welding the V guide

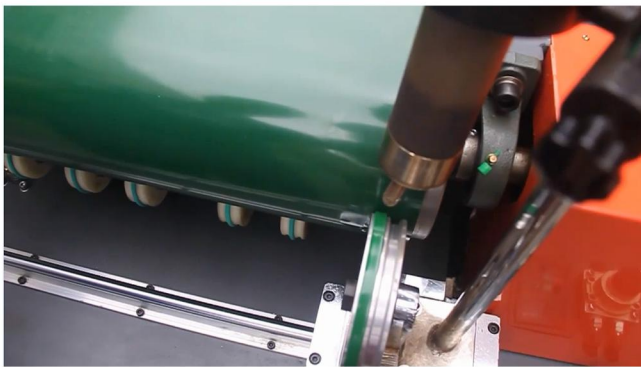

⚠️ WARMING

The speed no need to be fast,Too fast speed will uneven heating, affecting the welding effect

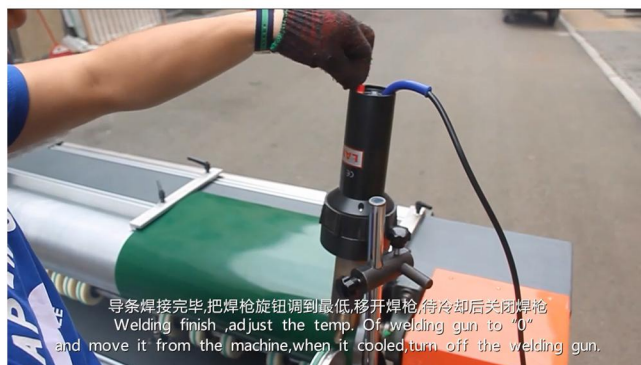

When the welding completed,don't close the welding gun asap,you should turn the heating level to "0" first,when the temperature cooled down,then closed.

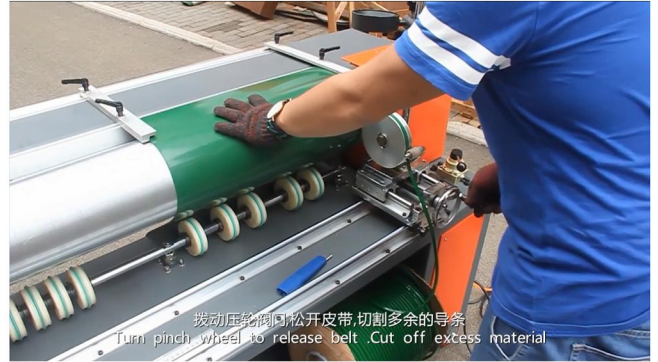
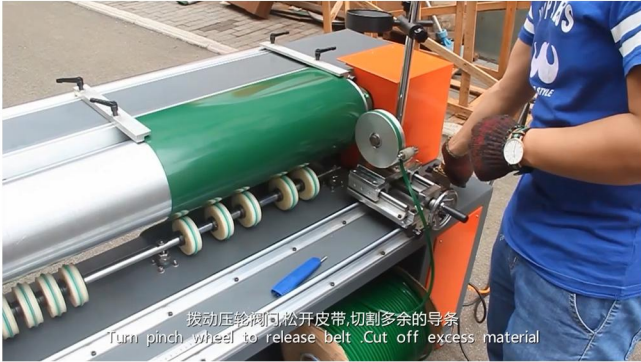

13.Welding Finished,check the quality

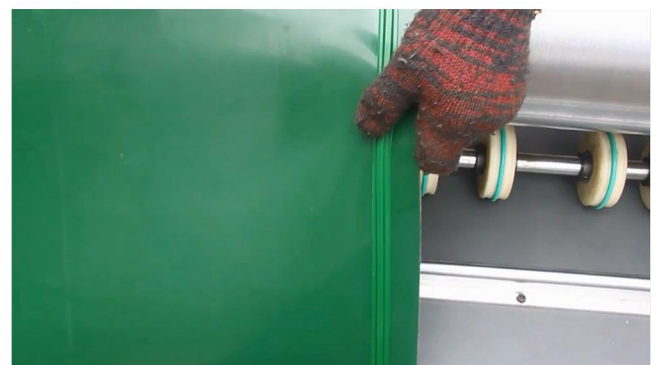
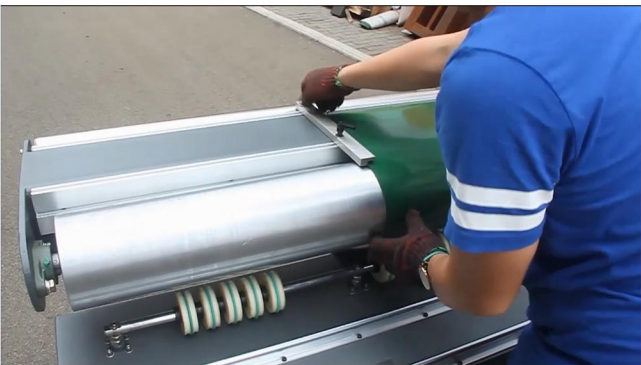

Suggestion

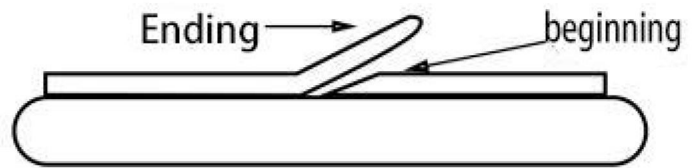

Make a cant on the beginning,it will make a good nice V guide

Disconnect device

- s.After the welding operation is completed, the following items should be noted :
- i:Release pressure wheel
 - ii:Turn off the machine power , remove the wall plug
 - iii:Turn off the air compressor, disconnect the connecting tube
 - iv:After the heat gun cool, shut off the power of the heat gun then remove the wall plug.

HOLO



HOLO Grinding Tool

Option 1:

- Grinding Equipment
1PH 220V, grinding on the bottom fabric and then welding the V guide.



Option 2:

- Welding Gun
1PH 220V, 1.6KW, Equipped with a dedicated round head

HOLO

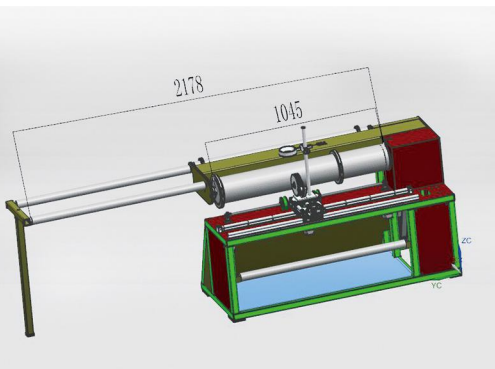

HOLO QB 1000

Option 3:

- 2Meter Extension frame
Easy installation, helpful For belts up to 2 meters wide welding.

Common problems and solutions

NO.	Description	Photo	

SAFETY CONSIDERATIONS

This application procedure is not intended to supersede any company construction or safety standards. This procedure is offered only to illustrate safe application for the individual. FAILURE TO FOLLOW THESE PROCEDURES MAY RESULT IN PERSONAL INJURY OR DEATH.

Do not modify this product under any circumstances.

This product is intended for use by trained technicians only. This product should not be used by anyone who is not familiar with, and not trained to use it.

When working in the area of energized lines, extra care should be taken to prevent accidental electrical contact.

For proper performance and personal safety, be sure to select the proper size PREFORMED product before application.

PREFORMED products are precision devices. To insure proper performance, they should be stored in cartons under cover and handled carefully.



HOLO V GUIDE WELDING MACHINE

HOLO



Factory scene

© WENZHOU HOLO INDUSTRIAL EQP MFG CO.,LTD

Room 201, Building 3, NO.188 Wangxin Road Dongshan Street RUIAN Wenzhou

ZHEJIANG, China

Web: <http://www.holobelt.com>

Tel:(86)0577 65682000 Fax:(86)0577 65916651